

REVISIONS				
ZONE	REV	DESCRIPTION	DATE	APPROVED
	A	ADD GROUND WIRE TO ENGINE	2/9/10	SMH
		NOTES		

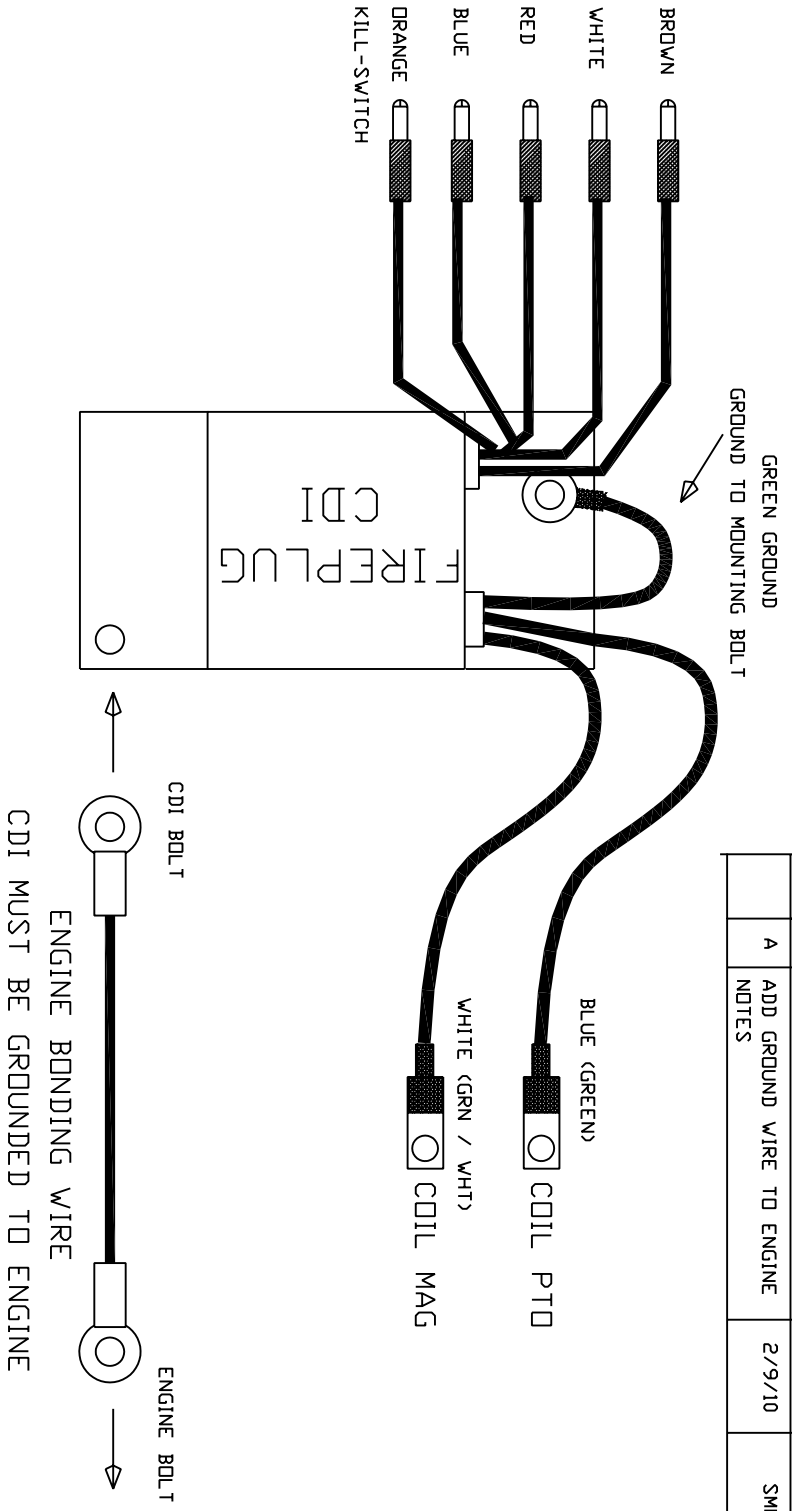

NOTES:

** A BOND / GROUND WIRE IS NEEDED FROM CDI TO ENGINE **
 ** GROUND RING TERMINAL TO CDI MOUNTING BOLT SUGGEST USING B8ES / B9ES IN PLACE OF RESISTOR PLUGS CDI WILL MOUNT IN FACTORY LOCATION USING DIAGONAL HOLES **

T-BOLT STATOR VALUES:
 BLUE TO GROUND = 8K-OHMS / LOW-SPEED WINDING
 RED TO GROUND 100-OHMS / HI-SPEED WINDING
 TRIGGER (BROWN TO WHITE) = 800-OHMS

FIREPLUG CDI WIRING		MERCURY T-BOLT	
HEWELT	SIZE	FSQM NO.	DWG NO.
5/29/07	SCALE		SHEET
			REV